



Enriching Lives

# KIRLOSKAR DIESEL ENGINES

## Engine Model : 4K1080TA

No. of Cyls.	Bore x Stroke (mm)	Displacement (cc)	Gross Power Output Rating as per ISO3046 at 1500 RPM bhp (kW)		Suitable Power Rating for Generator at 0.8 pf	
			Prime	Standby	Prime	Standby
4	105 x 125	4330	156 bhp (114.8 kW)	171.6 bhp (126.3 kW)	100 kVA	110 kVA
					125 kVA	137.5 kVA

### Features -

- Designed for heavy duty applications
- Extremely reliable
- All service points like dipstick, lube oil filling, lube oil filter, fuel pump, injectors are on one side which is the cooler side. This adds to operator comfort.
- Lower operating cost
- Easy maintenance – higher uptime
- Superior design standards that minimize power deration even at high ambient temperatures.
- Winner of the frost & Sullivan Voice of Customer Award in the “Best Bang for Buck” category in the Indian Generating sets Market.

### **Ratings Definition:**

**Standby Ratings:** These ratings are applicable for supplying continuous electrical power (at variable load) in the event of a utility power failure. No overload is permitted on these ratings. The alternator on this model is peak continuous rated (as defined in ISO 8528-3)

**Prime Rating:** These ratings are applicable for supplying continuous electrical power (at variable load) in lieu of commercial purchased power. There is no limitation to the annual hours of operation and this model can supply 10% overload power for 1 hour in 12 hours.

**Continuous Rating:** These ratings are applicable for supplying power continuously to a constant load upto the full output rating for unlimited hours. No sustained overload capability is available for this rating.

**Power, Performance, Peace of Mind.**

KIRLOSKAR



Enriching Lives

## Engine Technical Data :

Physical Data	
Engine Make	Kirloskar
Engine Model	4K1080TA
Number of cylinders	4
Configuration	Inline
Type	Four stroke
Bore x Stroke (mm)	105 x 125
Displacement (cc)	4330
Cooling	Water cooled
Aspiration	Turbocharged
Compression Ratio	15.5 : 1
Starting Arrangement	12V Electric

Fuel System	
Type of fuel filter	Two stage spin on type
Governor Type	Electronic
Class of Governing	ISO 3046 Class A1 & ISO 8528-5, Class G2
Fuel pump type	Rotary
Fuel pump make	Stanadyne
Recommended Fuel	Class A2, High speed diesel
Fuel consumption at 100% load +5% tolerance (lit/hr)	26 (for 125kVA) / 24 (for 100kVA)
Fuel consumption at 75% load +5% tolerance (lit/hr)	21 (for 125kVA) / 19 (for 100kVA)
Fuel consumption readings are based on diesel fuel with a specific gravity of 0.85 and confirming to BS 2869, Class A2)	

Air System	
Air Filter Type	Dry type replaceable element
Air Volume required for Ventilation (m <sup>3</sup> /hr)	TBA
Combustion air flow (m <sup>3</sup> /hr)	TBA
Total Air Flow required for ventilation (m <sup>3</sup> /hr)	TBA
Total Fresh air required (m <sup>3</sup> /hr)	TBA

Lubrication System	
Type of lube oil filter	Full flow spin on type
Oil to be used	Multi grade 15W40
Oil pump type	Through G-rotor gear pump
Lub oil sump capacity (lit)	18
Lube oil consumption	0.3% of fuel consumption

Cooling System	
Cooling system capacity (lit)	21
Water pump type	Centrifugal
Radiator fan load (hp)	6.5

Electrical System	
Starting Arrangement	12V Electric
Starter	12V Electric
Starter Battery Rating	150 Amp-hr
Battery charging alternator	Engine mounted 12V battery charger
Battery charger amps	35

**Power, Performance, Peace of Mind.**



Enriching Lives

## Engine Dimensional Details :

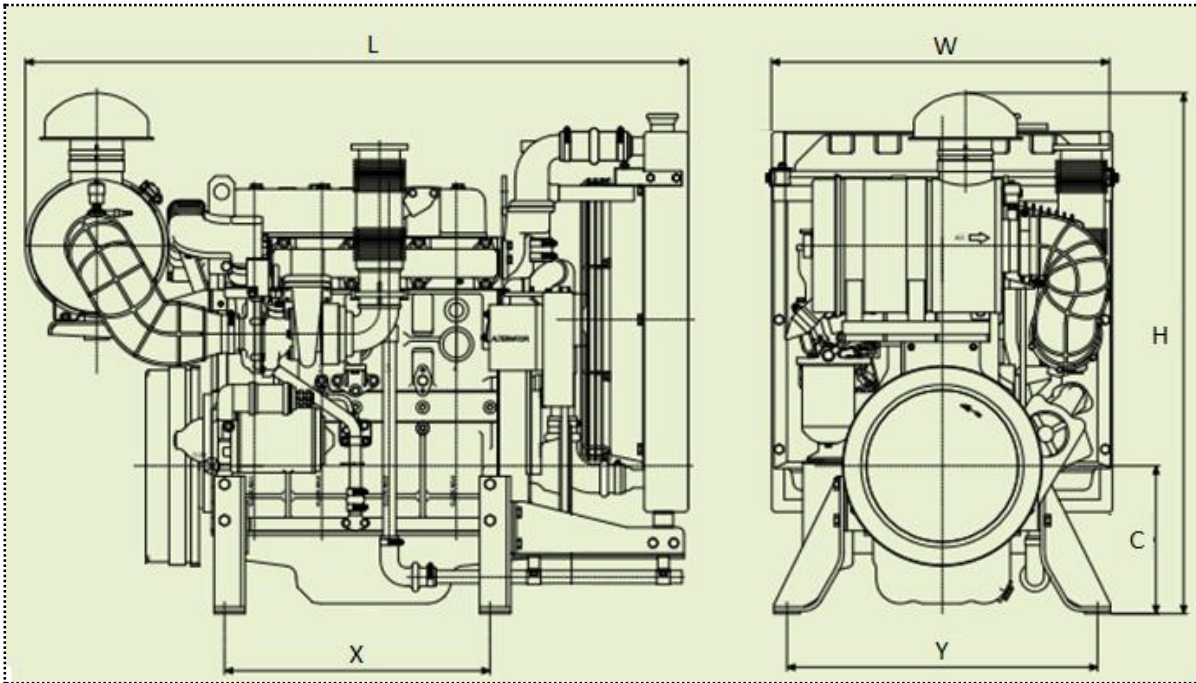

Dimensions in mm					
L	W	H	C	X	Y
1580	1020	1180	Please refer to engine GA drawing		

Weight Details	
Engine weight without radiator Gross / Net (kg)	670/ 585
Radiator and accessories weight Gross / Net (kg)	77 / 60

Coupling	
Flywheel	Suitable for SAE 11.5" disc
Housing	SAE3
Coupling disc	Not supplied



Enriching Lives

### **KIRLOSKAR OIL ENGINES LIMITED**

Head Office: Laxmanrao Kirloskar Road, Khadki, Pune 411 003, India.

Tel.: +91 20 2581 0341 / 534 Fax: +91 20 2581 3208 Website : [www.koel.co.in](http://www.koel.co.in)

### **KIRLOSKAR DMCC**

JBC-5, Cluster W, Jumeirah Lake Towers, P.O.Box 37745, Dubai. U.A.E

Tel.: +971 4 443 8591 Fax: +971 4 441 4532

Email: [enquiry@kirloskar.ae](mailto:enquiry@kirloskar.ae) Website : [www.kirloskar.ae](http://www.kirloskar.ae)

Kirloskar Oil Engines Limited reserved the right to change the design or specifications without notice.  
Contact your local distributor for more details.