



Enriching Lives

KIRLOSKAR DIESEL ENGINES

Engine Model : 6SL1500TA

No. of Cyls.	Bore x Stroke (mm)	Displacement (cc)	Gross Power Output Rating as per ISO3046 at 1500 RPM bhp (kW)		Suitable Power Rating for Generator at 0.8 pf	
			Prime	Standby	Prime	Standby
6	118 x 135	8860	248 bhp (182.5 kW)	272 bhp (200 kW)	200 kVA	220kVA

Features -

- Designed for heavy duty applications
- Extremely reliable
- All service points like dipstick, lube oil filling, lube oil filter, fuel pump, injectors are on one side which is the cooler side. This adds to operator comfort.
- Lower operating cost
- Easy maintenance – higher uptime
- Superior design standards that minimize power deration even at high ambient temperatures.
- Winner of the frost & Sullivan Voice of Customer Award in the “Best Bang for Buck” category in the Indian Generating sets Market.

Ratings Definition:

Standby Ratings: These ratings are applicable for supplying continuous electrical power (at variable load) in the event of a utility power failure. No overload is permitted on these ratings. The alternator on this model is peak continuous rated (as defined in ISO 8528-3)

Prime Rating: These ratings are applicable for supplying continuous electrical power (at variable load) in lieu of commercial purchased power. There is no limitation to the annual hours of operation and this model can supply 10% overload power for 1 hour in 12 hours.

Continuous Rating: These ratings are applicable for supplying power continuously to a constant load upto the full output rating for unlimited hours. No sustained overload capability is available for this rating.

Power, Performance, Peace of Mind.

KIRLOSKAR



Enriching Lives

Engine Technical Data :

Physical Data	
Engine Make	Kirloskar
Engine Model	6SL1500TA
Number of cylinders	6
Configuration	Inline
Type	Four stroke
Bore x Stroke (mm)	118 x 135
Displacement (cc)	8860
Cooling	Water cooled
Aspiration	Turbocharged After cooled
Compression Ratio	17.5 : 1
Starting Arrangement	24V Electric

Fuel System	
Type of fuel filter	Two stage element type
Governor Type	Mechanical
Class of Governing	ISO 3046 Class A1 & ISO 8528-5, Class G2
Fuel pump type	Inline
Fuel pump make	MICO - BOSCH
Recommended Fuel	Class A2, High speed diesel
Specific fuel consumption gm/bhp-hr (gm/kW-hr)	144 (196)
Fuel consumption at 100% load +5% tolerance (lit/hr)	45.98
Fuel consumption at 75% load +5% tolerance (lit/hr)	34.48
Fuel consumption readings are based on diesel fuel with a specific gravity of 0.85 and confirming to BS 2869, Class A2)	

Air System	
Air Filter Type	Dry type replaceable element
Air Volume required for Ventilation (m ³ /hr)	16605
Combustion air flow (m ³ /hr)	900
Total Air Flow required for ventilation (m ³ /hr)	17541
Total Fresh air required (m ³ /hr)	TBA

Lubrication System	
Type of lube oil filter	Full flow spin on type
Oil to be used	Multi grade 15W40
Oil pump type	Through G-rotor gear pump
Lub oil sump capacity (lit)	24
Lube oil consumption	0.3% of fuel consumption

Cooling System	
Cooling system capacity (lit)	43
Water pump type	Centrifugal
Radiator fan load (hp)	7

Electrical System	
Starting Arrangement	24V Electric
Starter	24V Electric
Starter Battery Rating	2x180 Amp-hr
Battery charging alternator	Engine mounted 24V battery charger
Battery charger amps	55

Power, Performance, Peace of Mind.



Enriching Lives

Engine Dimensional Details :

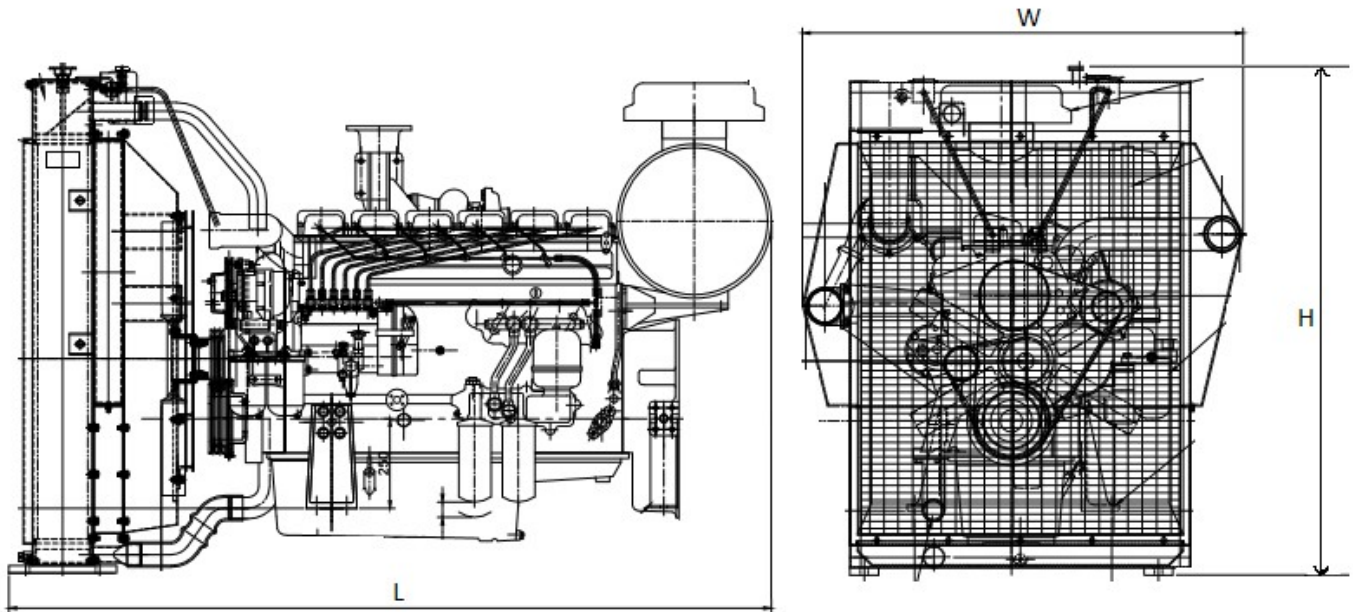

Dimensions in mm			
L	W	H	For engine mounting dimensions please refer the respective rating GA drawing
2125	1228	1431	

Weight Details	
Engine weight without radiator Gross / Net (kg)	1210 / 950
Radiator and accessories weight Gross / Net (kg)	300 / 200

Coupling	
Flywheel	Suitable for SAE 14" disc
Housing	SAE1
Coupling disc	Not supplied



Enriching Lives

KIRLOSKAR OIL ENGINES LIMITED

Head Office: Laxmanrao Kirloskar Road, Khadki, Pune 411 003, India.
Tel.: +91 20 2581 0341 / 534 Fax: +91 20 2581 3208 Website : www.koel.co.in

KIRLOSKAR DMCC

JBC-5, Cluster W, Jumeirah Lake Towers, P.O.Box 37745, Dubai. U.A.E
Tel.: +971 4 443 8591 Fax: +971 4 441 4532
Email: enquiry@kirloskar.ae Website : www.kirloskar.ae

Kirloskar Oil Engines Limited reserved the right to change the design or specifications without notice.
Contact your local distributor for more details.